

Phantom Superecology LUXOR

AVAILABLE ENGINES AND POWER RATINGS

Luxor M-780	Luxor M-612
26 hp Diesel (Water)	52 hp Diesel (Water)

DIMENSIONS in mm

	A	B	C	D	Empty weight kg
Luxor M780	1400	1800	1135	1700	610
Luxor M780 + Microdoser	1400	1800	1135	1700	625
Luxor M612	1400	2290	1160	2100	1100
Luxor M612 + Microdoser	1400	2700	1160	2100	1115

- weights and dimensions may vary depending on the type of set-up

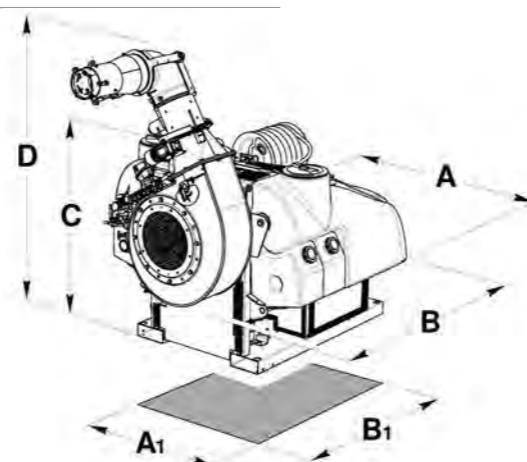

FRAME BASE DIMENSIONS in mm.

	A1	B1
Luxor M780	910	1245
Luxor M780 + Microdoser	910	1800
Luxor M612	920	2050
Luxor M612 + Microdoser	920	2700

	LUXOR M780	LUXOR M612
Product Tank Capacity	400 lt	400 lt
Circuit Washer Tank Capacity	30 lt	30 lt
Hand Wash Tank Capacity	15 lt	15 lt
Fuel Tank Capacity	15 lt	15 lt
Fan capacity in m3/hour	9000 a 80 m/s	18000 a 80 m/s
Pump flow rate (3 membranes) in lt/m	40	40
Pump pressure in Bar	0 - 40	0 - 40
Horizontal range in m (up to)	25	30-35
Vertical range in m (up to)	18	20-25

- we reserve the right to make changes without prior notice

MARTIGNANI S.r.l.

Via Fermi, 63
Zona Industriale Lugo 1 - 48020
S. Agata sul Santerno (RA) Italy
T +39 0545 230 77 | F +39 0545 306 64
martignani@martignani.com



WWW.MARTIGNANI.COM

Technology,
Functionality
and avant-garde
design

Invincible for

PEST-CONTROL
(mosquitoes, flies, cockroaches, ants, wasps, locusts, etc..)
LARVICIDAL TREATMENTS
ULV TREATMENTS
GREEN CARE
ODOURS TREATMENT (in composting areas, dumps, etc..)

ELECTROSTATIC[®]
AGRO SPRAY SYSTEM

SINCE 1981 First in Europe



New mist blowers
PHANTOM SUPERECOLOGY LUXOR
FOR ENVIRONMENTAL HYGIENE SPECIALISTS



MARTIGNANI
FOR A GREENER WORLD

SINCE 1958

The exclusive advantages of the **MARTIGNANI** System, appreciated by experts and professional users in the environmental hygiene and public ground care sphere.



The perfect and **uniform micronization** produced using a unique type of pneumatic nozzle, with a large diameter (4 mm), and **fade-free functionality, no wear**, no clogging, no maintenance.

Precision liquid metering unit with graduated stainless steel scale for instantaneous metering of any volume to be distributed, from 50 to 1300 l/hour at a single pressure of 1.5 bar. The best and most congenial system, which can also be used in conjunction with the "I.M.E." **micro-pump to meter pure chemicals**, featuring separate reservoirs (also controlled in l/hour but at 10 bar instead of the 1,5 bar of the sprayer circuit. This means no risk of damages and the elimination of the delicate back-pressure valve).

High performance centrifugal fans, with an exclusive design, able to provide a coverage with several hundreds of microscopic droplets per cmq at even very low volumes (50 l/hour) and up to distances that are impossible to achieve with any air conveyance sprayer with **high pressure nozzles** and **calibrated plates**.

Device for **Electrostatic charging of micro droplets** (patent B091C0001444 and B093A000444), the first produced in Europe (1981) and the **only one multi-tested in Italy** by three research institutes with published phytotherapeutic results. Now it is widespread and well-known throughout the world as Number 1 when it comes to innovative methods concerning the **application of plant protection products with respect for the environment and operators' health**.



ELECTROSTATIC[®]
AGRO SPRAY SYSTEM

POWER AIR FOGGER KIT

(patent B092U000163), used in conjunction with the fluid dynamic action of the Martignani fans to deliver an ultra-powerful, no drifting screen of mist. It can also be used with very lightweight **moplen** pipes.

ULV NOZZLE KIT (Ultra Low Volume) – Patent N° B02006A000457

The "U.L.V." KIT to distribute products at Ultra Low Volume is ideal to protect from stray adult insects, to combat locust emergencies in deserts and to eliminate odours in com-



1. Precision **METERING UNIT**
2. **Omni-directional SPRAY GUN** with 90° + 360° rotation
3. **BLOWER** with electrical rotation through 260°
4. Quickly **TRANSPORTED FRAME** with fork guide
5. "Long Life" professional **CONTROLS**
6. **FUEL TANK** (15L)
7. **400L TANK** with hand-washing(15L) and circuit flushing (30L)
8. Clearly visible (from both sides) **LEVEL GAUGE**
9. **Double FILLING PORT**
10. Exclusive **MUFFLER** in Stainless Steel
11. **HOSE REEL ROLLER** with manual, electric operation or automatic with spring (40,50,100 m)

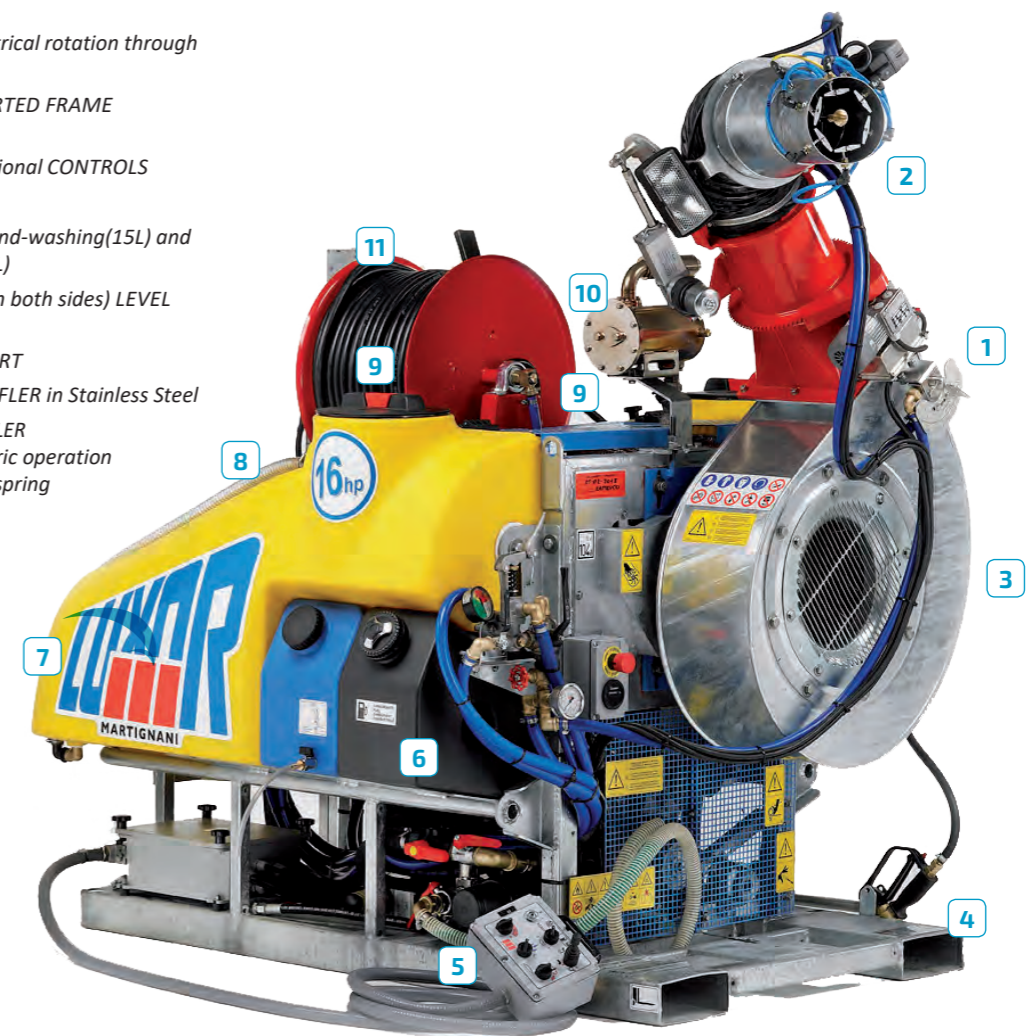

PHANTOM SUPERECOLOGY LUXOR

posting areas, dumps, etc. It consists of a mist-blowing nozzle on the central axis of the spray gun's exit port and it simply works thanks to the air pressure blowing from the spraying head (therefore without using an air compressor).

Spray Gun with PLUG 'N PLAY System in order to combine different types of spray heads:

- Round classic head (Long-range treatment)
- Fan head (wide-angle treatment with reduced range on shrubs, hedges, little masts, ecc..)
- Double head (bilateral treatment)

Remote control without wiring

A mist blowing unit that requires practically no maintenance.

