



**SMART  
SOLUTIONS**  
*for a*  
**MODERN &  
ECO-FRIENDLY  
FARMING**

*Electrostatic Backpack Sprayer*

## **MARTIGNANI K800**



Ideal for targeted disinfestation treatments, public parks and gardens, environmental hygiene and agriculture.



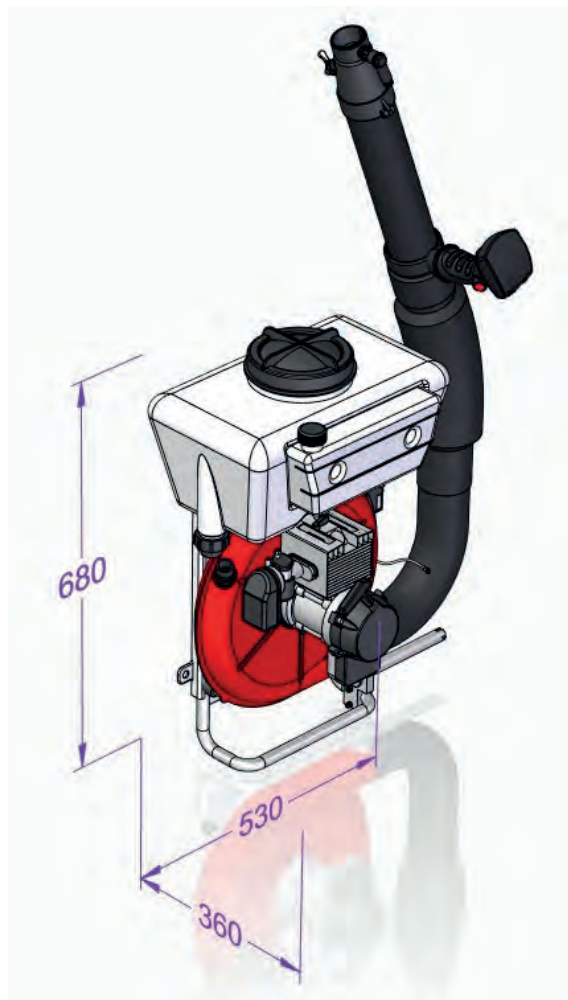

## TECHNICAL SPECIFICATIONS

- **One-cylinder two-stroke engine:** 72.4 cc – 3.7 kW (5 hp) – 6700 rpm
- **Manual recoil starter**
- **Electronic ignition**
- **Fan air low:** 1000 m<sup>3</sup>/h
- **Fuel tank:** 1.7 l
- **Chemical mix tank:** 14 l
- **Air speed:** 100 m/s
- **4-position fluid metering valve with variable delivery:** from 0.5 to 3 l/min.
- **Ergonomic multifunctional joystick with:** engine stop, accelerator, fluid release, double safety for gases and fluids
- **Empty weight:** Kg. 12 approx.
- **Vertical range:** up to 8 m
- **Horizontal range:** up to 10-12 m

Made of high quality materials that make it durable and easy to use, the Martignani K800 Backpack Sprayer is fitted with an electrostatic recovery device that allows the treatment to be optimized. By accurately directing the spray, it reduces the waste of active agents and losses due to drift, thereby safeguarding the environment and the health of the operator. A completely eco-friendly piece of equipment.

Optional: Ultra-Low Volume Nozzle that allows micronization to be reduced even further, and therefore the amount of mixture delivered.

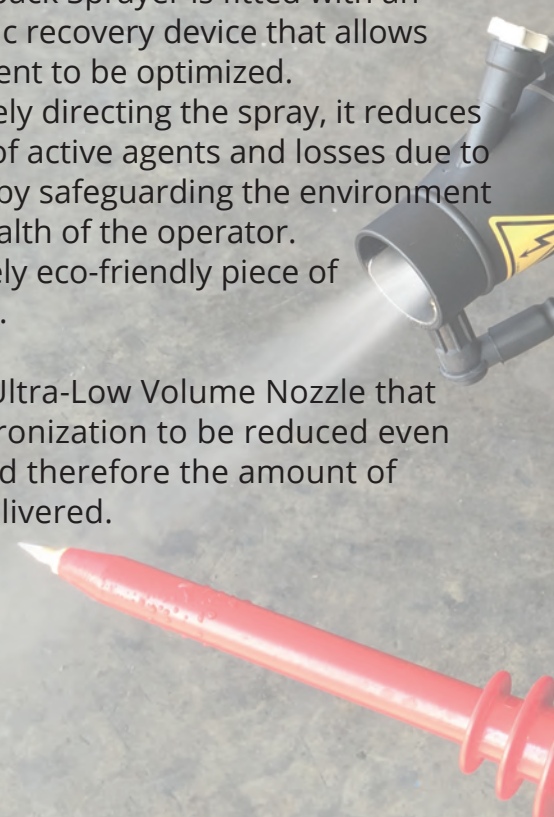



Standard Nozzle



Ultra-Low Volume Nozzle (optional)



# 5 GOOD REASONS

FOR CHOOSING  
MARTIGNANI  
MIST BLOWERS  
WITH THE  
ELECTROSTATIC  
DEVICE



## OPERATING ADVANTAGES, COMPARED TO A CONVENTIONAL SPRAYER:

- Drift losses on atmosphere - 85%
- Run-off losses on the ground - 70%
- Perfect and uniform distribution of the agrochemical (minor quantity required per hectare)
- Increased efficiency
- Adaptable to any cultivation form



## SAVINGS:

- Time: about 60%
- Labour: about 60%
- Chemicals: about 50%
- Water: about 90%



## PRODUCTION QUALITY:

- Healthier crops
- Fruits without imperfections
- Fruits and wine with "zero" or minimum legal chemicals residues



## LIFE QUALITY:

- Environmental impact reduction
- Contamination dangers for operators: about - 75%
- Guarantee of health for the consumers



## TESTIMONIALS:

- Tested (with published results) worldwide by several eminent Research Institutes (three in Italy)

## INTERNATIONAL FAIRS MULTI AWARD WINNING:

- SIMA - Paris - France (Golden Medal 1985)
- EIMA - Bologna - Italy (Technical Innovation 1988, 2004, 2014)
- AGRIBEX - Bruxelles - Belgium (Silver Spike 1992)
- FIERAGRICOLA - Verone - Italy (Technical Innovation 1994, 1995, 2004, 2016)
- EIMA - Bologna - Italy (Environment Award 2016)
- EIMA - Bologna - Italy (Technical Mention 2021)



TREATED WITH

**ELECTROSTATIC**<sup>®</sup>  
AGRO SPRAY SYSTEM

K 800 MARTIGNANI



**MARTIGNANI**<sup>®</sup>

**MARTIGNANI S.r.l.**

Via Fermi, 63  
(Zona Industriale Lugo 1) 48020  
S. Agata sul Santerno (RA) ITALY  
Tel. +39 0545 23077  
Fax +39 0545 30664  
martignani@martignani.com  
[www.martignani.com](http://www.martignani.com)

