



**SMART
SOLUTIONS
for a
MODERN &
ECO-FRIENDLY
FARMING**

3P Mounted Electrostatic Sprayer

PHANTOM

*With "SMS"
System (Smart
Maintenance System)
PATENT N. 102020000023995*



MARTIGNANI S.r.l.

Via Fermi, 63 (Zona Industriale Lugo 1)
48020 S. Agata sul Santerno (RA) Italy
Tel. +39 0545 23077 - Fax +39 0545
30664 martignani@martignani.com
www.martignani.com



MUCH MORE THAN AN AIR BLAST-SPRAYER

The most suitable and effective method to treat fruit trees, vines and field crops. The Phantom mist blowers spray a fine mist that penetrates dense foliage, covering leaves, fruit and twigs alike with a fine and uniform coating of chemical.

No bare areas - no wasteful chemical run-off - no chemical residues on fruits, vegetables, grapes, wine, etc ...

TREATED WITH



...pioneers since 1981

CONSTRUCTION FEATURES

The Martignani Phantom Electrostatic 3P Mounted Sprayer, Regular or Slim, with its innovative **SMS (Smart Maintenance System)**, guarantees access in seconds to the technological compartment of the machine for ordinary and extraordinary maintenance operations. In this type of machine, maintenance operations are complicated, forcing the user to disassemble parts of the machine. Martignani's SMS system overcomes this limitation, maintaining both the advantages of reduced space and improved stability, and quick and easy inspection and/or maintenance.

The new Martignani Phantom Electrostatic Mounted Sprayer with **SMS** System consists of a first frame for the tank connected to the tractor's three-point hitch, and a second frame for the technological compartment (driveline, pump, fan, diffusers, nozzles, etc.). The second frame is connected to the first (fixed) one by a system with hinges and threaded pins that allows access to the technological compartment.

With the help of a common spanner, by loosening the two locking nuts, it is possible to position the technological part of the machine from the working position to the maintenance position and vice versa in just a few seconds. The **SMS** system allows the user to carry out the following inspection or scheduled maintenance operations easily, conveniently, quickly and safely, for example:

- Inspection of driveline components;
- Gearbox oil change;
- Pump and hydraulic circuit inspection;
- Checking for correct belt tension;
- Greasing of cardan joints;
- Etc.

DIFFERENCE BETWEEN 3P MOUNTED PHANTOM REGULAR AND SLIM

The Martignani Phantom 3P Mounted Sprayer is also available in a SLIM version, very compact and light, able to treat those crops where passages are particularly narrow. Compared to the REGULAR version, the SLIM sprayer has these features

- Reduced lateral encumbrance (max. 100 cm / 40 inch)
- Ideal for high-density or very narrow row spacing crops (vineyards, berries, greenhouse crops, etc.)
- Available with 300 l (80 US gallons) and 400 l (100 US gallons) tanks.



TECHNICAL DATA

KOMBY

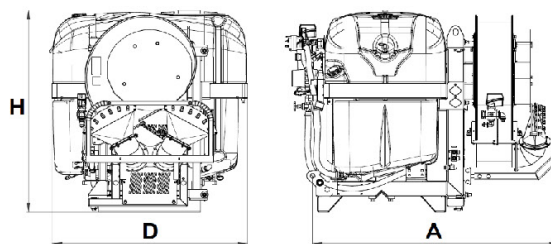

CALIFORNIA

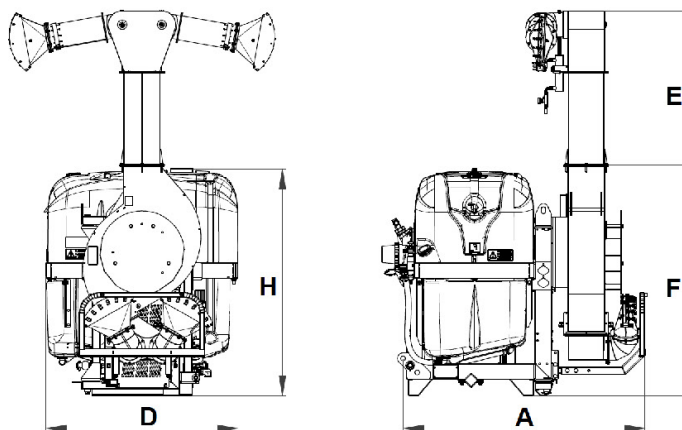

Descrizione	KOMBY					CALIFORNIA				
	SLIM		REGULAR			SLIM		REGULAR		
	Capacity (lt)									
Tank	300	400	400	500	600	300	400	400	500	600
Circuit Rinsing Tank	47									
Hand Wash Tank	15									
	Weight (kg)									
Empty Mass	395	405	395	405	415	510	515	510	515	520
Fully Loaded Mass	760	870	860	967	1058	870	980	970	1077	1163
	Dimensions (mm)									
A	1500					1500				
D	1000		1210			1000		1210		
E (colonna 400 mm)						770				
E (colonna 600 mm)						970				
E (colonna 850 mm)						1220				
F						1500				
H	1400	1550	1245	1340	1460	1400	1550	1245	1340	1460
Total Machine Height	E + F					E + F				
	Mist Blower Specifications									
Tractor Power Required	18 kW (24 HP)					36 kW (50 HP)				
Absorbed Power by the Sprayer	13 kW (17 HP)					22 kW (30 HP)				
Pump Flow Rate (l/m)	170					170				
Operating Pressure (bar)	1,5					1,5				
Fan Air Capacity (m3/h)	6550					10500				
Air Speed (m/s)	from 65 to 85					from 65 to 85				
Fan Rotation Speed (revs./min.)	from 3600 to 4250					from 3600 to 4250				
Sound Power Level db (A)	104					104				

AVAILABLE CONFIGURATIONS

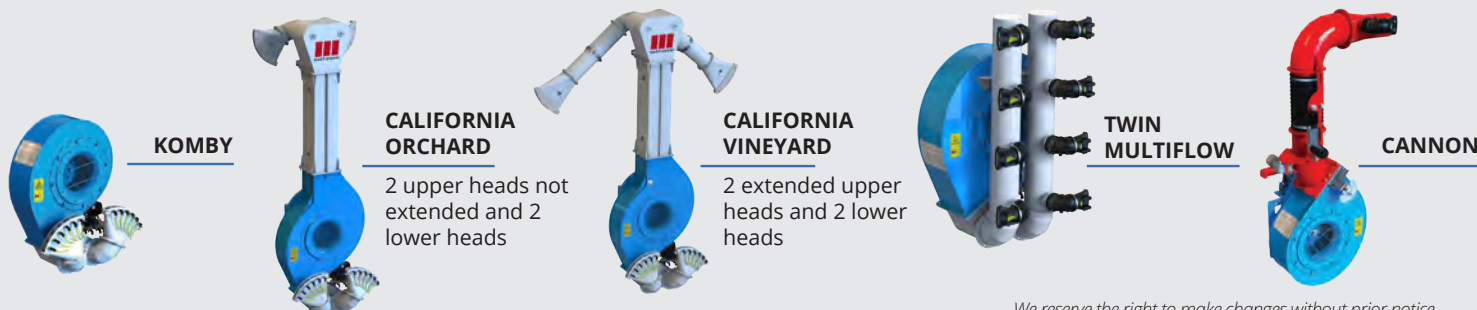

KOMBY

CALIFORNIA ORCHARD

2 upper heads not extended and 2 lower heads

CALIFORNIA VINEYARD

2 extended upper heads and 2 lower heads

TWIN MULTIFLOW

CANNON

5 GOOD REASONS

FOR CHOOSING
MARTIGNANI
MIST BLOWERS
WITH THE
ELECTROSTATIC
DEVICE



1 OPERATING ADVANTAGES, COMPARED TO A CONVENTIONAL SPRAYER:

- Drift losses on atmosphere - 85%
- Run-off losses on the ground - 70%
- Perfect and uniform distribution of the agrochemical (minor quantity required per hectare)
- Increased efficiency
- Adaptable to any cultivation form



2 SAVINGS:

- Time: about 60%
- Labour: about 60%
- Chemicals: about 50%
- Water: about 90%



3 PRODUCTION QUALITY:

- Healthier crops
- Fruits without imperfections
- Fruits and wine with "zero" or minimum legal chemicals residues



4 LIFE QUALITY:

- Environmental impact reduction
- Contamination dangers for operators: about - 75%
- Guarantee of health for the consumers



5 TESTIMONIALS:

- Tested (with published results) worldwide by several eminent Research Institutes (three in Italy)

INTERNATIONAL FAIRS MULTI AWARD WINNING:

- SIMA - Paris - France (Golden Medal 1985)
- EIMA - Bologna - Italy (Technical Innovation 1988, 2004, 2014)
- AGRIBEX - Bruxelles - Belgium (Silver Spike 1992)
- FIERAGRICOLA - Verone - Italy (Technical Innovation 1994, 1995, 2004, 2016)
- EIMA - Bologna - Italy (Environment Award 2016)
- EIMA - Bologna - Italy (Technical Mention 2020/2021)



PHANTOM 3P MOUNTED



MARTIGNANI

MARTIGNANI S.r.l.

Via Fermi, 63
(Zona Industriale Lugo 1) 48020
S. Agata sul Santerno (RA) Italy
Tel. +39 0545 23077
Fax +39 0545 30664
martignani@martignani.com

www.martignani.com



TREATED WITH



...pioneers since 1981